

# Mushroom Hydrocyclone Assemblies



- **POWERFUL HYDROCYCLONES**
- **FINE SOLIDS SEPARATION**
- **SMALL FOOTPRINT**
- **SIMPLE TO INSTALL**
- **EASY TO MAINTAIN**
- **REDUCED CAPITAL COSTS**

## TYPICAL APPLICATIONS

- **Source and Process Water**
- **Industrial Minerals**
- **Metallic Minerals**
- **Power**
- **Food**
- **Tunnelling**
- **Vehicle Washing**
- **Textiles**
- **Fertilizers**

Where space is at premium our Mushroom assemblies are the ideal solution. They are a compact and lightweight solution to packaging a number of hydrocyclones within the smallest footprint. The configuration can range from 10, five inch hydrocyclones to 80, two inch or 180 one inch.

Mushroom assemblies are fitted with the Salter Cyclones range of powerful one to five inch hydrocyclones which are designed for high performance and optimum efficiency.

Our range of hydrocyclones provide continuous efficient service in a number of applications including desliming ahead of flotation, classifying, degritting or dewatering.

All our hydrocyclones are offered with a full range of vortex finder, spigot sizes and body extensions for maximum optimisation of results. Body extensions can be fitted to give increased capacity and a finer cut point.

The assemblies are simple to install, with less interconnecting pipework and space requirements than conventional designs, reducing overall project costs. They are a cost effective solution to achieving an efficient separation at a fine cut point when treating large flow rates.

Maintenance is simple. The quick release cover gives fast access to the hydrocyclones. Component parts can quickly and easily be changed, should the feed alter or, for planned maintenance. Spigots are easily accessible and can quickly be changed out, should there be a blockage, with a snap-off/snap-on movement without having to remove the cover.

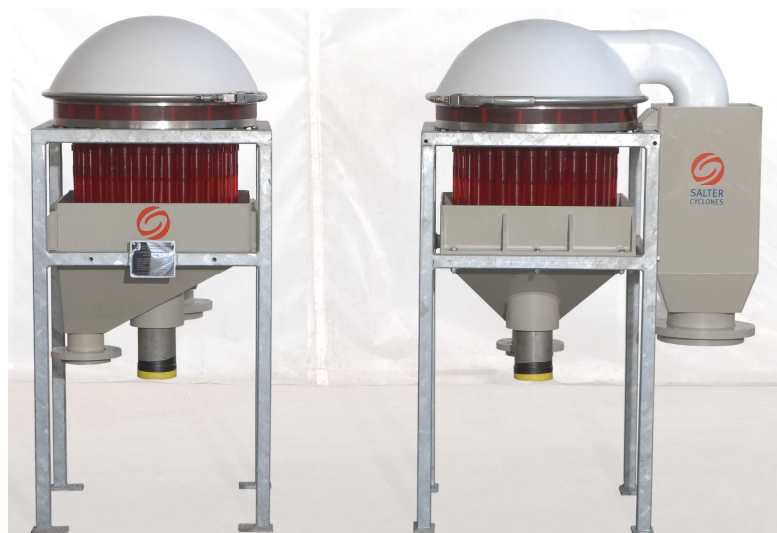

# Mushroom Hydrocyclone Assemblies

Mushroom assemblies can be installed as individual units, which are available with a stand and underflow launder, or alternatively as radials of 4 or 6 assemblies complete with frame, distributor, overflow and underflow launders and isolation valves. Capacities can easily be adjusted by replacing operating hydrocyclones with blanks or vice versa.

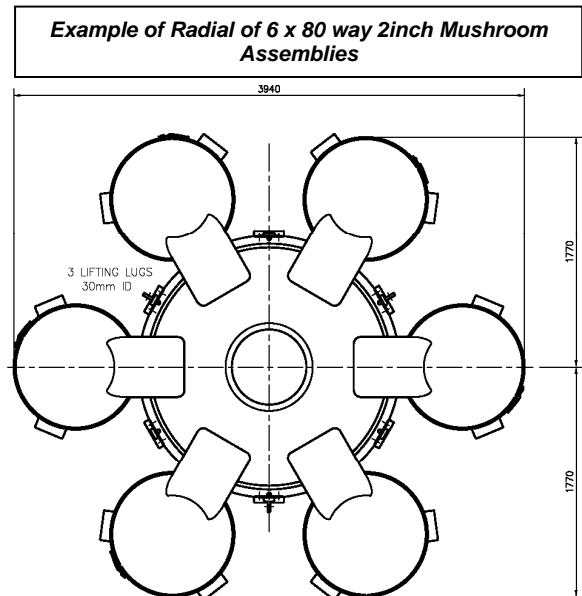
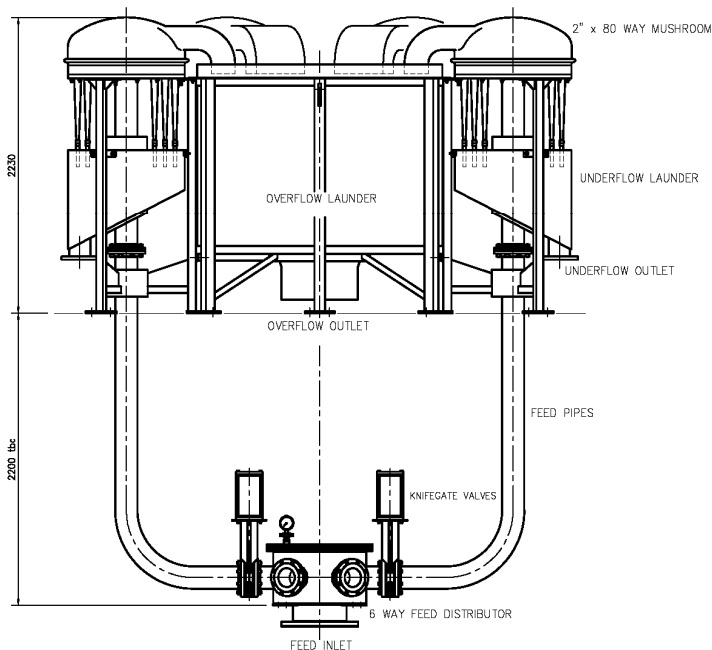

## FULL TECHNICAL SUPPORT

After a thorough assessment of feed data, we will recommend the most suitable hydrocyclones for the project. We can offer trials which may include laboratory, pilot plant and full scale studies either on-site or at our own facilities or a combination of both.

We have a multi-disciplined team of design engineers, metallurgists, project managers, on-site commissioning engineers and after-sales service staff offering customer support throughout the lifetime of the project.

We offer a range of services from laboratory testing, equipment selection, design and build, to commissioning and supply of spares.

Our skill is in delivering total quality solutions for individual separation problems.

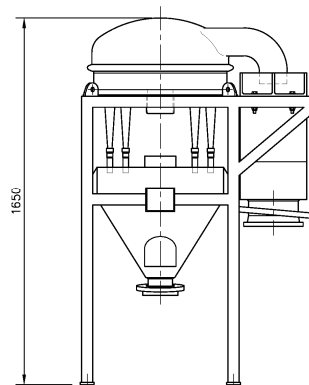
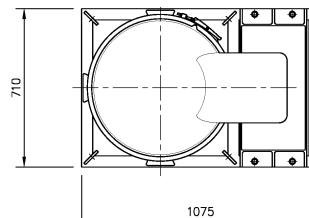

**Example of stand-alone Mushroom Assembly with stand and launder**

© Salter Cyclones Ltd 2012

The above information is offered as a guide only. No warranty or guarantee, expressed or implied, is made regarding the capacity, performance or suitability of any product

**For more information on this or any other Salter Cyclones product, please contact :**

**Salter Cyclones Ltd, Cheltenham Film & Photographic Studios, Hatherley Lane, Cheltenham GL51 6PN, United Kingdom**

**Tel: + 44 1242 697771 Fax: + 44 1242 690895 Email: sales@saltercyclones.com**